



The SP-350 HD

The upgraded design features a moveable cabin for increased visibility and requires no tear down or setup, meaning the machine is ready to work when it arrives onsite. Other enhancements include 4 cameras on the machine to monitor the off-sides, shaker and loading of material, and an upgraded undercarriage for more stability.





SCREEN AREA
60 ft²



WEIGHT
115,000 lb



HORSEPOWER
350 HP

Specifications

Engine

Type	Caterpillar
Model	C-9 ACERT Tier IV Final
Net flywheel power (DIN 6270)	350 HP
Governed speed	2,100 rpm
Displacement	567.5 in ³ (9.3 L)

Hydraulic System

Main pumps:	H1P100 Danfoss
	2 independent hydrostatic variable pumps travel
Maximum capacity	52.8 US gal/min (200 L/min)
Maximum operating pressure	6,090 p.s.i. (390 bar)
- 1 hydrostatic variable pump escalator - H1P100 Danfoss	
Maximum capacity	52.8 US gal/min (200 L/min)
Maximum operating pressure	4,061 p.s.i. (280 bar)
- 1 hydrostatic variable pump load sensing service - S45-E100 Danfoss	
Maximum capacity	52.8 US gal/min (200 L/min)
- Maximum operating pressure	4,351 p.s.i (300 bar)

Transmission

Type	Hydrostatic
Motors	A6VE107
Final drives	715C3B
Maximum speed	
- 1 speed	1.1 mph (1.78 km/h)
- 2 speed	2.15 mph (3.46 km/h)

Fluid Capacities

Fuel tank	136 US gal (515 L)
Hydraulic tank	196 US gal (742 L)

Dimensions

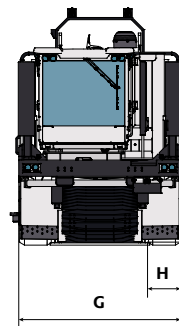
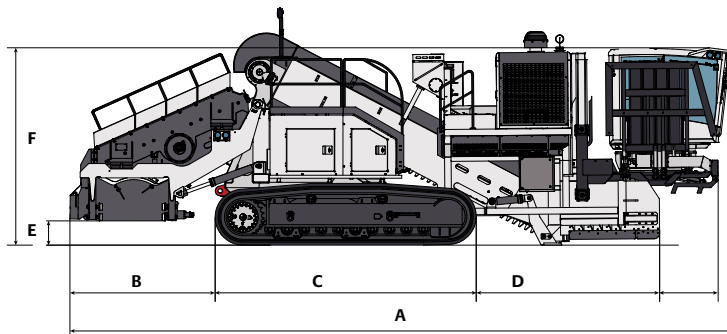

A	40.2' (12.3 m)
B	8.8' (2.7 m)
C	18.1' (5.5 m)
D	8.1' (2.5 m)
E	1.5' (44.8 cm)
F	12' (3.6 m)
G	9.8' (3 m)
H	2' (61 cm)

Escalator

Type	Hydrostatic, operator controlled, variable speed
Chain Adjusters	Berco LH44
Reversible double chain escalator with steel shoes	
Shoes width	53.3 in (138 cm)

Screen

Width	5.9 ft (1.8 m)
Length	10.4 ft (3.16 m)
Area	60 ft ² (5.57 m ²)

Controls

Type	Pilot operated
Safety	Emergency shut-off
Optional	Video monitor system
	Full remote control

Conveyor Belt

Bilateral hydraulic extension slide	
Type	Rubber
Width	33.4 in (85 cm)
Length	19.3 ft (5.9 m)
Variable speed	0 - 420 mt/min
Rotation capability	Reversible
Transmission	Hydraulic variable speed
Hydraulic motors	OMS 160

Electric System

Operating voltage	24 V
Maintenance free supplied batteries	2



2200 Post Oak Blvd., Ste. 1400, Houston, TX 77056

Main 281.457.4400 | U.S. Toll Free 800.383.2666 | sales@superiormftg.com | www.superiormftg.com